



MULTIJETFUSION TECNOLOGIA E APPLICAZIONI

Stefano Drago
NKE

Organizzato da



I limiti della stampa 3D fino ad oggi



FEDERAZIONE NAZIONALE
IMPRESE ELETTROTECNICHE
ED ELETTRONICHE



Velocità

TEMPO DI PRODUZIONE

- Il tempo di stampa è ore o giorni
- Necessita di tempo per le post-lavorazioni



Part Performance

PRESTAZIONI DEL PEZZO

- Finitura superficiale e dettagli
- Precisione dimensionale
- Proprietà meccaniche inferiori al pezzo prodotto in maniera tradizionale e **anisotrope**



Costi

COSTO TOTALE PEZZO

- Monopolio materiali = \$\$\$\$
- Costo macchina
- Costo operatore per post-processing

COME FUNZIONA

Material coating

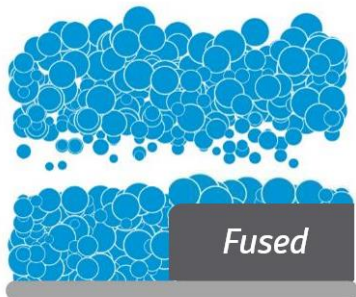

Apply agents

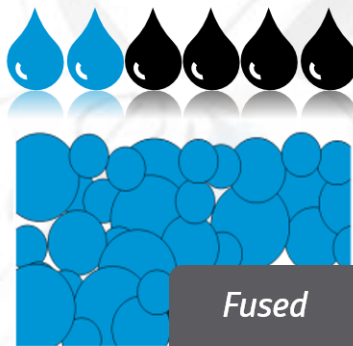

Apply energy

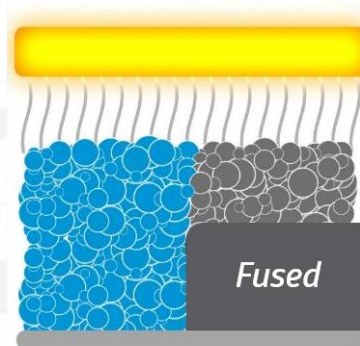

Fusion

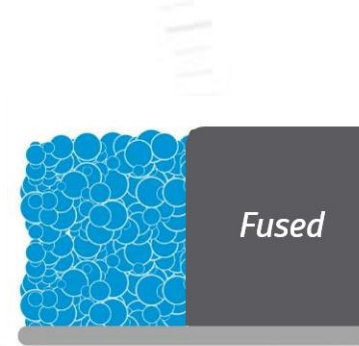

VOXEL e AGENTI DI FUSIONE – CONCETTO E FUNZIONE

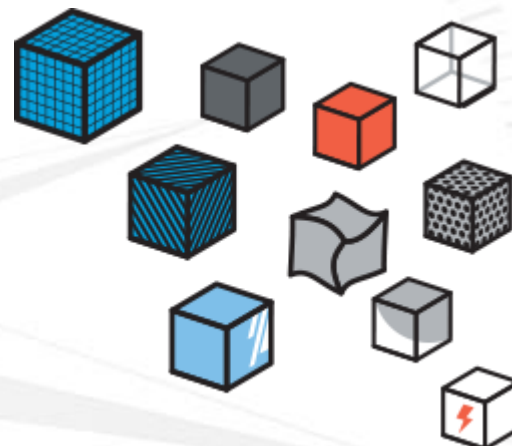
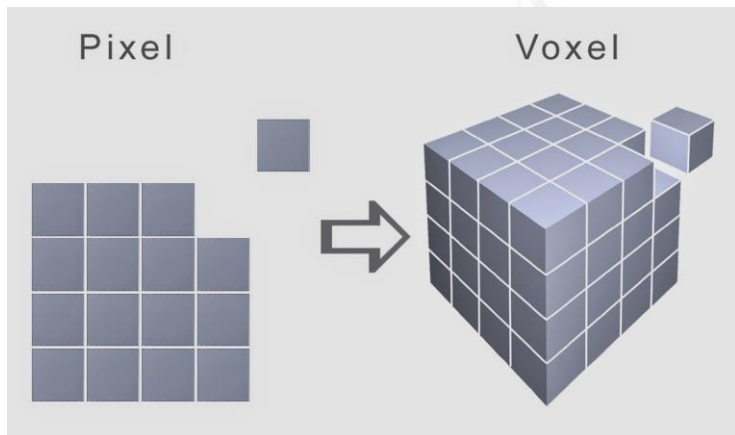

I vantaggi della tecnologia MJF



- Produttività
- Velocità
- Costo
- Facilità di utilizzo
- Qualità e performance componenti

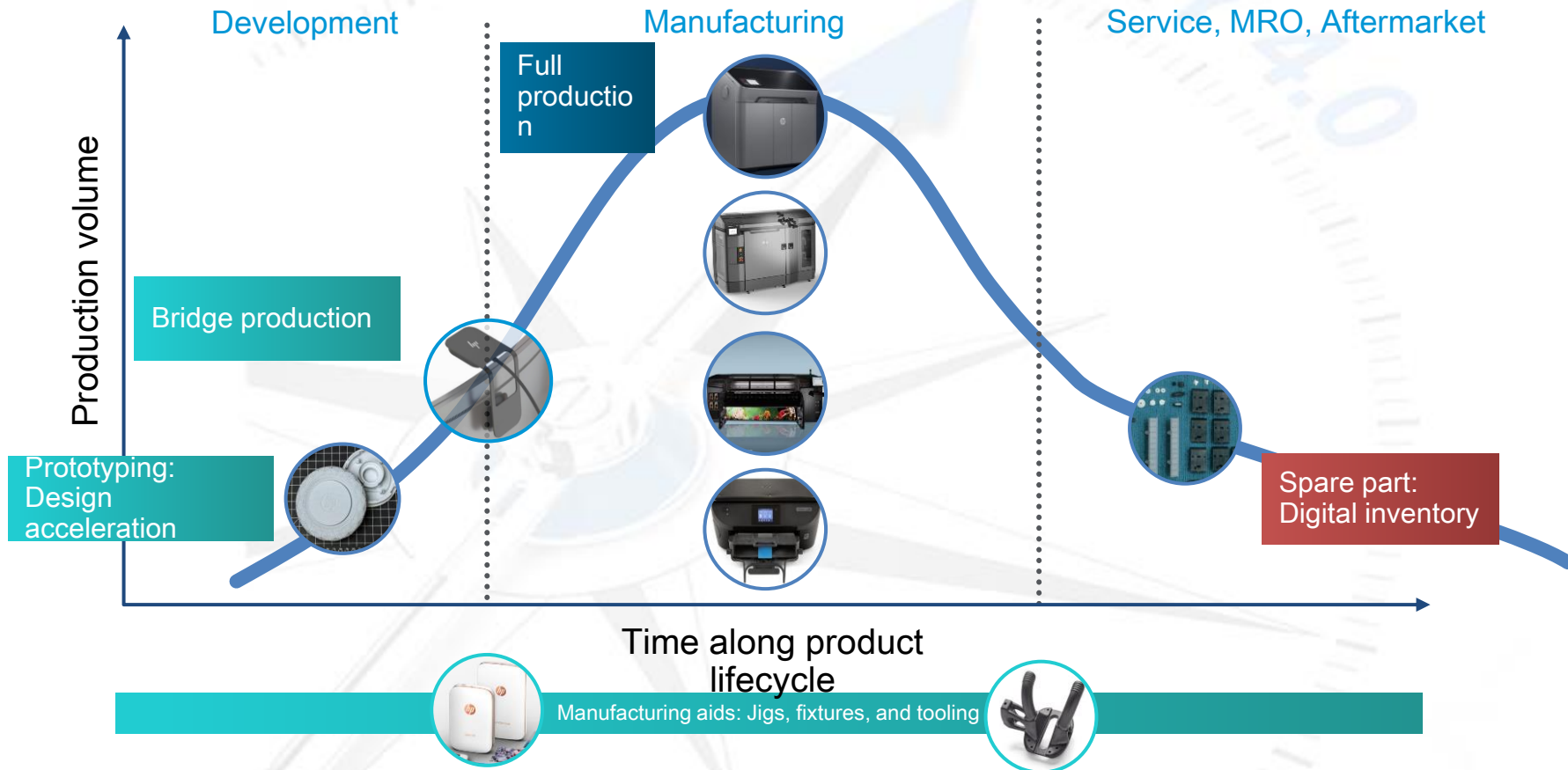

PRODUCT LIFECYCLE APPLICATIONS



3D High Reusable Polyamides Performance summary

Product	HP 3D HR PA 12	HP 3D HR PA 12GB	HP 3D HR PA 11
Tensile Strength XYZ (Stress) MPa	48	31	52 ★
Tensile Modulus XYZ (Stiffness) Mpa	1,800	2,700-2,800 ★	1,800
Elongation at break XY (%) (Elasticity)	20%	7,8%	50% ★
HDT XY -Z(@ 1,82MPa, in °C) (Heat Deflection Temperature)	95-95	111-118 ★	54-54
Izod Impact notched XY (@ 3.2 mm, 23°) KJ/m ²	3,5	2,9	6 ★
Reusability TCO advantage	80% ★	70%	70%
Differentiation vs PA12	<ul style="list-style-type: none"> The best performance & reusability ratio Water tightness USP Class I-VI 	<ul style="list-style-type: none"> Stiffness Dimensional stability Better HDT Nice Surface finishing 	<ul style="list-style-type: none"> Renewable source origin Better elongation and impact Nice look & feel, specially color uniformity 



FEDERAZIONE NAZIONALE
IMPRESE ELETTROTECNICHE
ED ELETTRONICHE



OPEN PLATFORM

Bringing down the barriers to **advance widespread 3D printing adoption** across industries through materials innovation with the **Multi Jet Fusion "Open Platform"**



INDUSTRY 4.0



Prototyping



Production

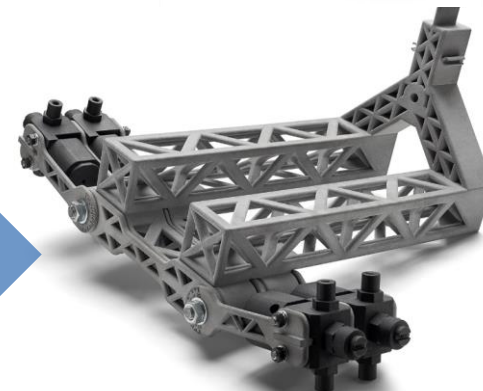



FEDERAZIONE NAZIONALE
IMPRESE ELETTROTECNICHE
ED ELETTRONICHE



Markets and applications



TRANSPORTATION



INDUSTRIAL



MEDICAL



CONSUMER



Markets and applications

TRANSPORTATION

EV BATTERY
COOLING



MOTORBIKE
MANIFOLD



SUPPORT



INDUSTRIAL

ROBOTICS/MACHINERY



TOOLING



GRIPPERS



MEDICAL

DENTAL ALIGNERS



ORTHOTICS



PROSTHETICS



CONSUMER

TECHNOLOGY
ACCESSORIES



SPORTS
EQUIPMENT



PERSONALIZED /
CUSTOM
FOOTWEAR



PRODOTTI DI SERIE CUSTOMIZZATI



FEDERAZIONE NAZIONALE
IMPRESE ELETTROTECNICHE
ED ELETTRONICHE

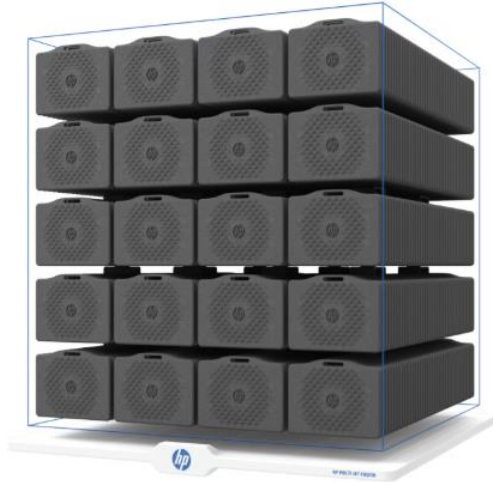

Settore medicale



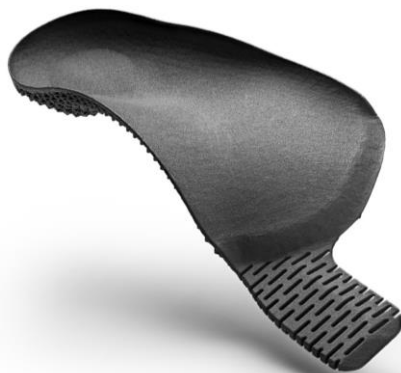



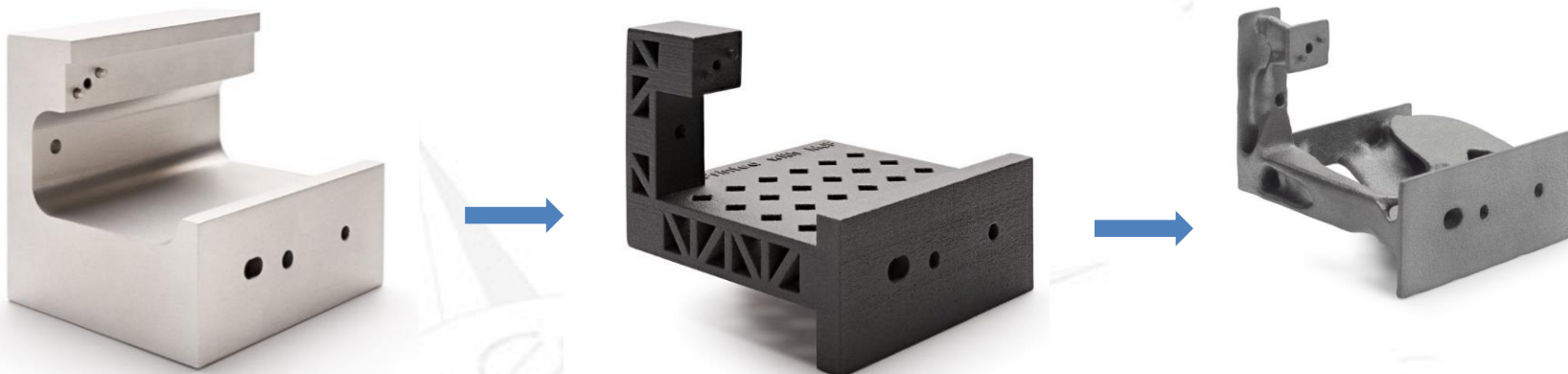

Personalizzazione

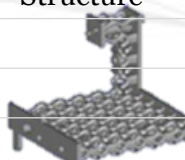
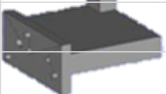

Supporto per HP Large Printer Generative design

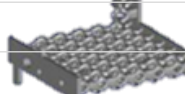
Parte in Multi Jet Fusion 85% più leggera, 70% più economica



	CNC	MJF				
	Aluminum	Solid	Topology Optimized	Topology + Lattice	Lattice Structure	Final
Volume (cm ³)	129.44					43.91
Weight (g)	355					55
Cost	\$22					\$5.90

Sistemi di presa

IAM
INTERNATIONAL
ADVANCED
MANUFACTURING 3D HUB



GIMATIC

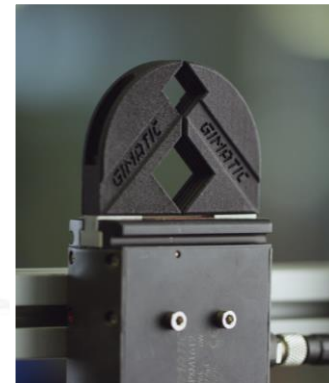



FEDERAZIONE NAZIONALE
IMPRESE ELETTROTECNICHE
ED ELETTRONICHE



Pre-serie

PIUSI



- Prototipazione
- Pre-serie
- Produzione di componenti per piccole serie
- Produzione di prodotti innovativi

Alluminio – versione originale per Benzina, Diesel e Kerosene



Contaltri PIUSI
K400

HP MJF HR PA12 – componente riprogettato per Adblue



Attrezzature, dime, maschere, staffaggi..

Riduzione numero di componenti e costi. aumento performance. velocità di realizzazione

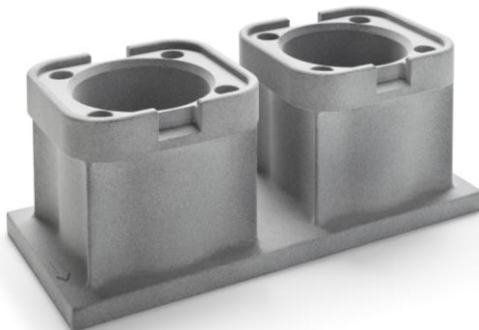
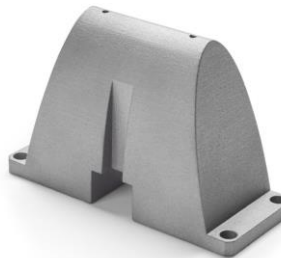

Soluzioni per la lavorazione del legno e altri materiali

- Prototipi funzionali: accelerazione sviluppo prodotto, nuovi concept
- Preserie: test, validazione e clienti beta
- Componenti finali: *“componenti finali dal peso fino ai 200 g in lotti da 100 pezzi sono più economici in MJF”*

componenti speciali: personalizzazione e riduzione dei costi



Attrezzature linea produzione testine di stampa

Riduzione n componenti e costi, aumento performance, velocità di realizzazione

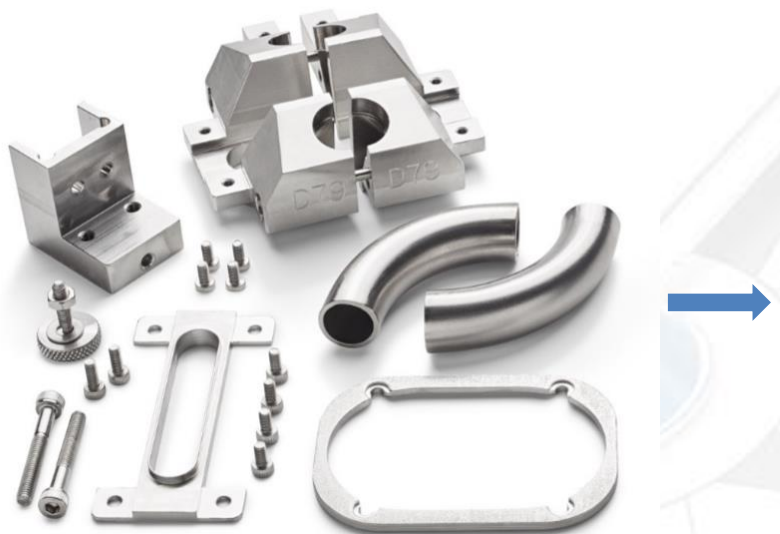

- **DIMENSIONS**
X: 3.91 in / 9,93 cm
Y: 3.72 in / 9,45 cm
Z: 2.68 in / 6,82 cm
- **MATERIAL**
HP 3D High Reusability PA
12 GB
- **POST PROCESSING**
Bead Blasting
- **TOTAL COST PER PART**
CNC Machined part: \$450
HP 3D MJF part: \$18
95% Overall cost reduction
- **WEIGHT REDUCTION**
CNC Machined part: 575 g.
HP 3D MJF part: 52 g.
90% Overall weight reduction
- **DELIVERY TIME**
CNC Machined part: 3-5 Days
HP 3D MJF part: 24 h.

Soluzioni per la verniciatura a polveri

- Prototipi funzionali: accelerazione sviluppo prodotto, nuovi concetti
- Componenti finali

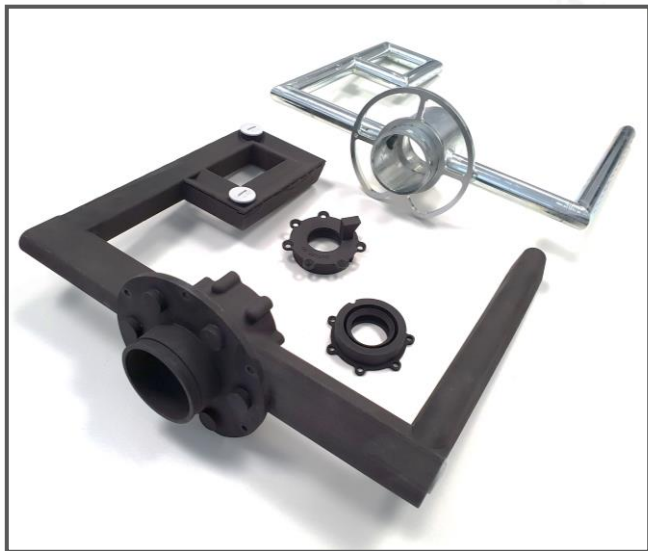

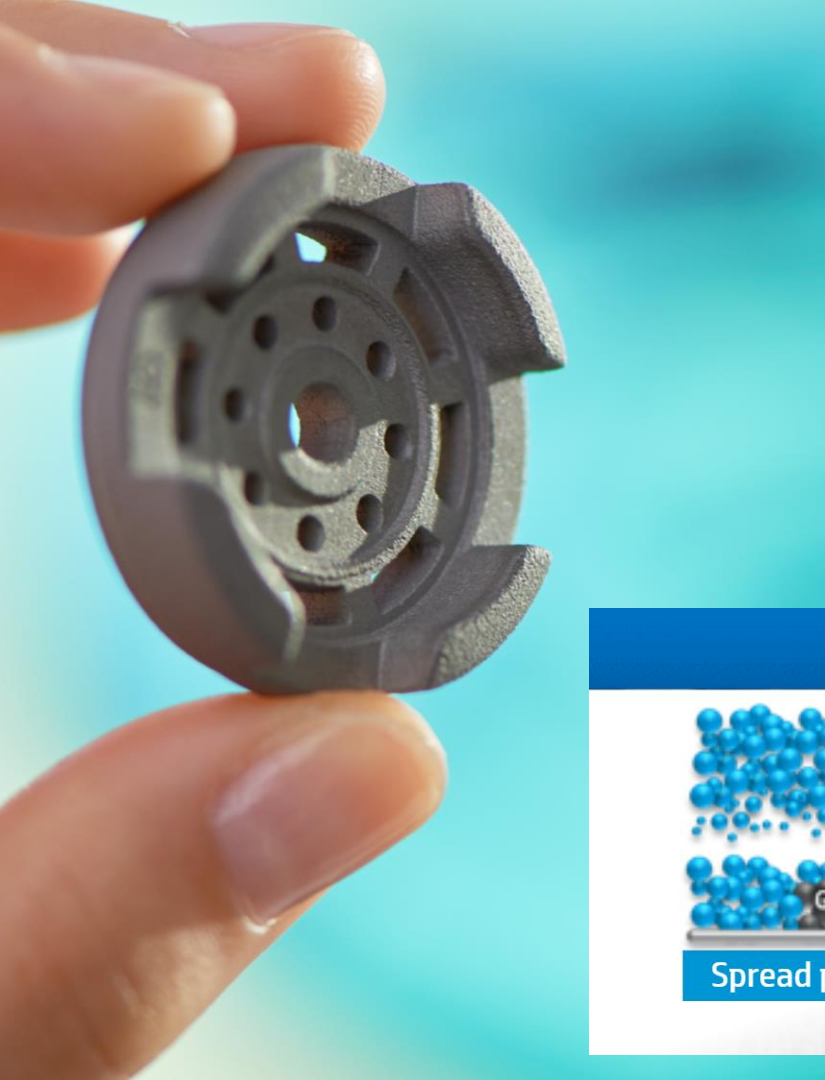

INDUSTRY

Introducing HP Metal Jet technology

Technology preview

HP Metal Jet

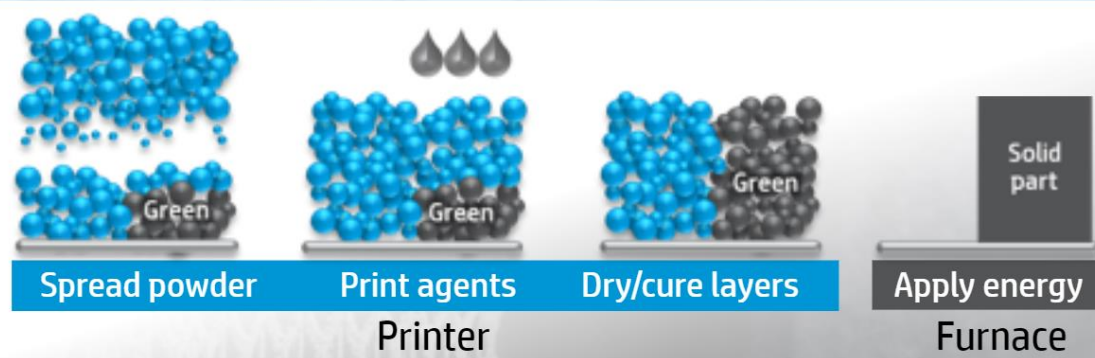

Starting with stainless steel 316L

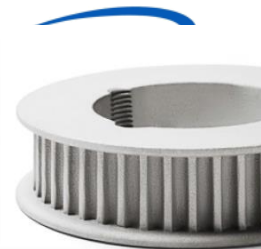

Quality

Good surface quality²

Ra 4-7 μ m
Rz 25-40 μ m

Mechanical Properties

Fulfill all requirements of ASTM and ISO standards

Elongation at break over 40%

Yield strength above 200 MPa

Ultimate tensile strength above 500 MPa

Homogenous microstructure³

Expected: no anisotropic mechanical properties (according to microstructure)

Low porosity (less than 0.5%)⁴

- 1) Based on benchmarks July 2018
- 2) Improved to other benchmarked additive processes such as DMD, LBPF, EBPF
- 3) Based on EBSD measurements of 2 samples
- 4) Based on optical cross-section analysis

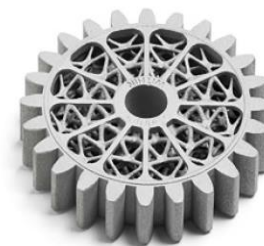



Grazie