



pininfarina

Lowie Vermeersch, Direttore Design

STYLING



Synergy between advanced styling and innovative technology





ENGINEERING



...from styling definition to engineering sign-off...

MANUFACTURING



...a flexible, lean, dedicated niche cars manufacturing...















pininfarina



pininfarina



pininfarina



pininfarina



pininfarina



pininfarina

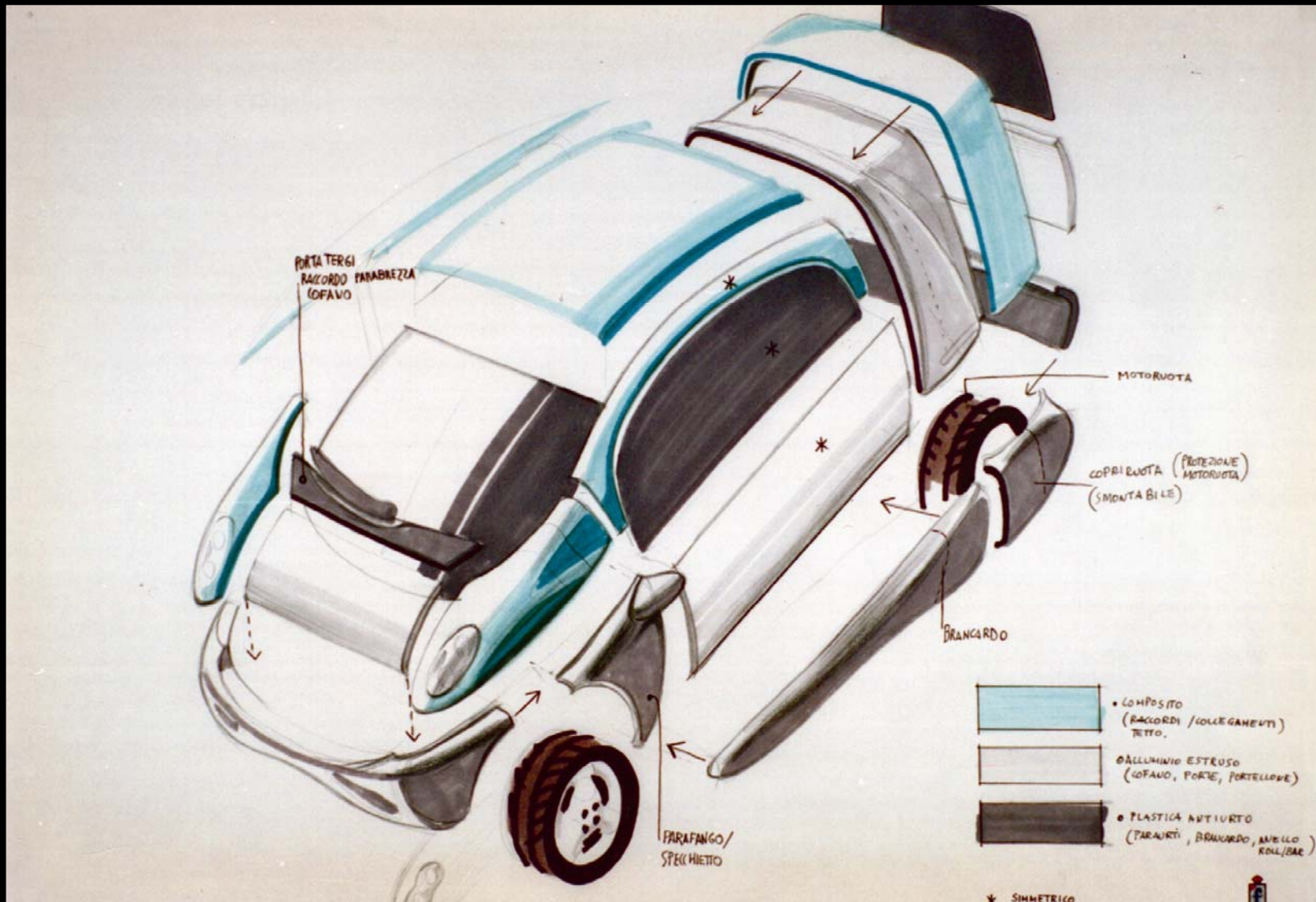

pininfarina



pininfarina



pininfarina



pininfarina



pininfarina



pininfarina



pininfarina

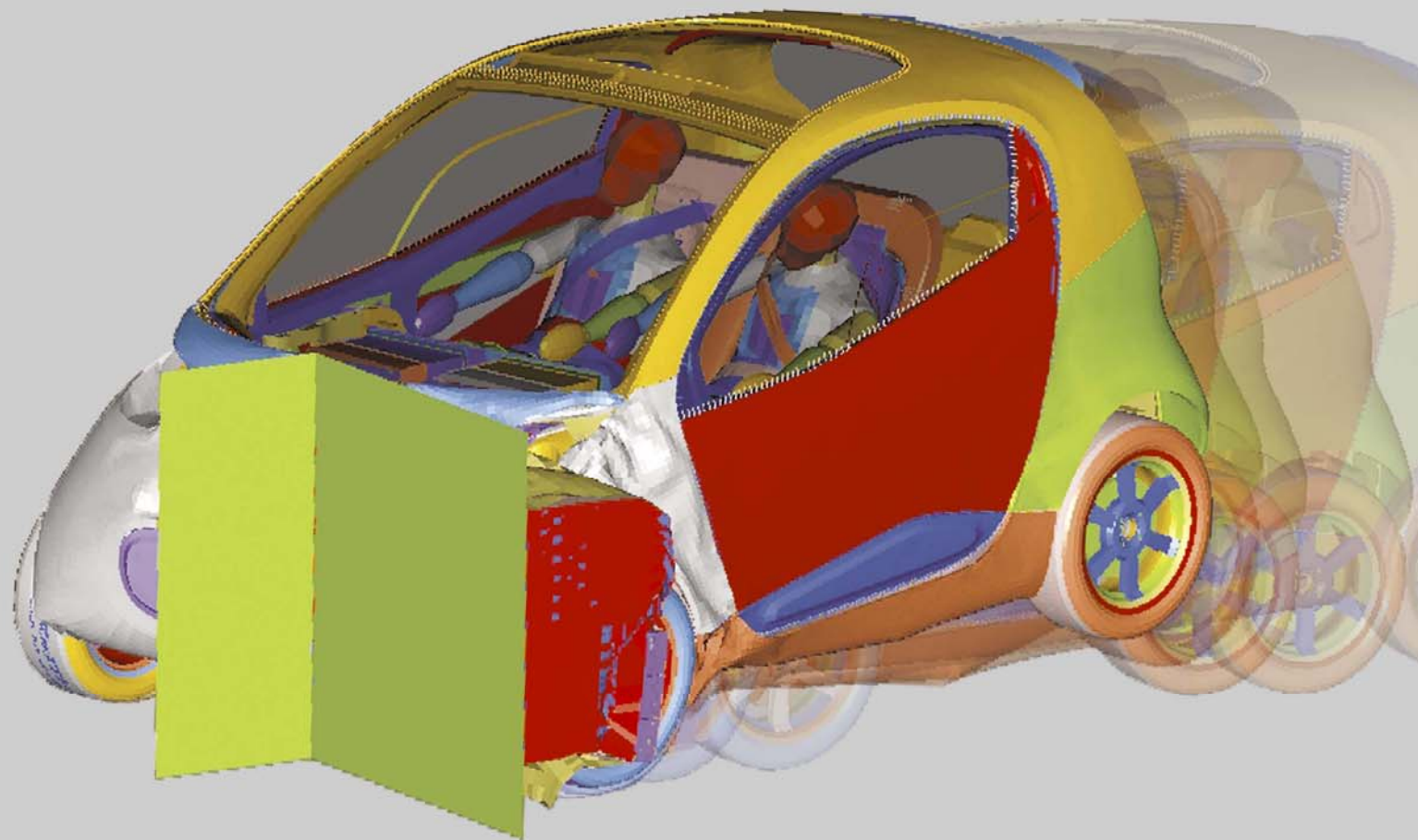

pininfarina



pininfarina



pininfarina



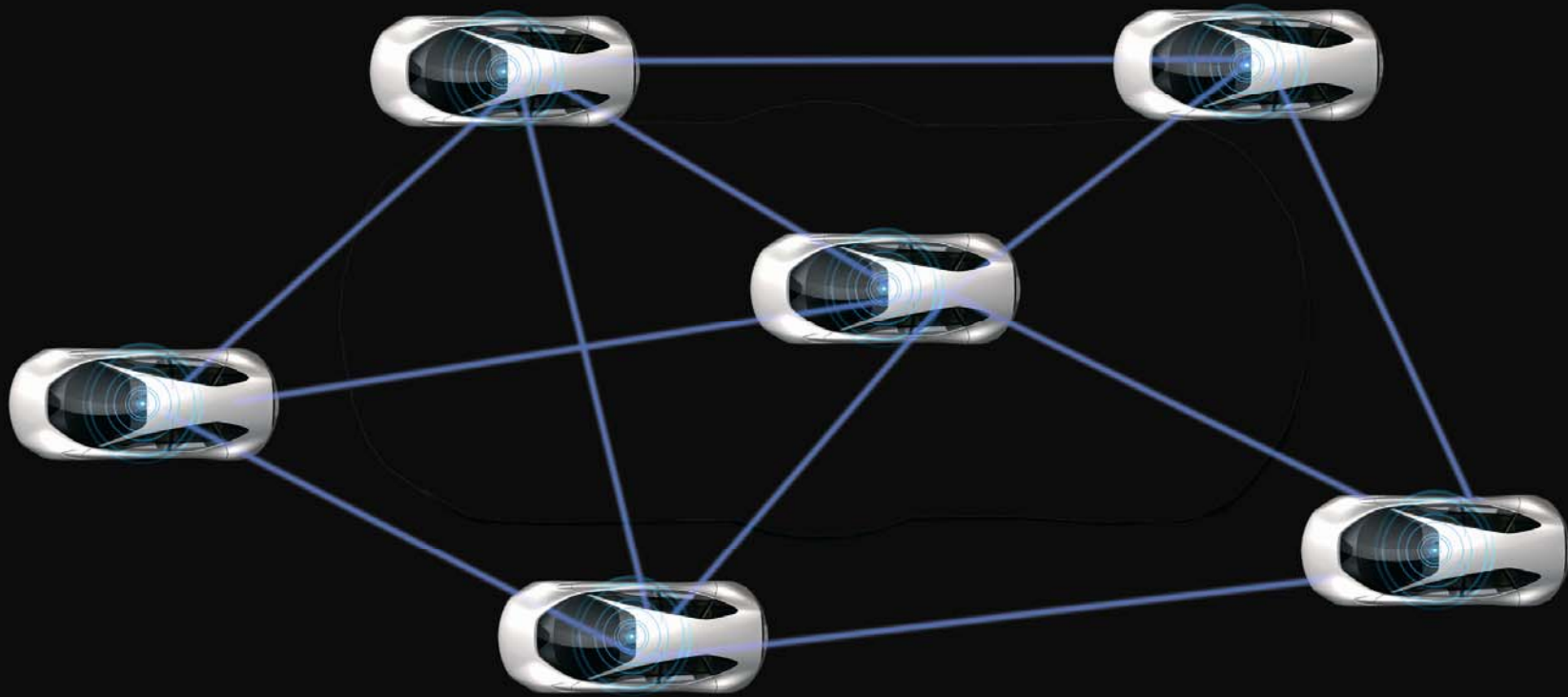

pininfarina

Bluecar®

MOODBOARD

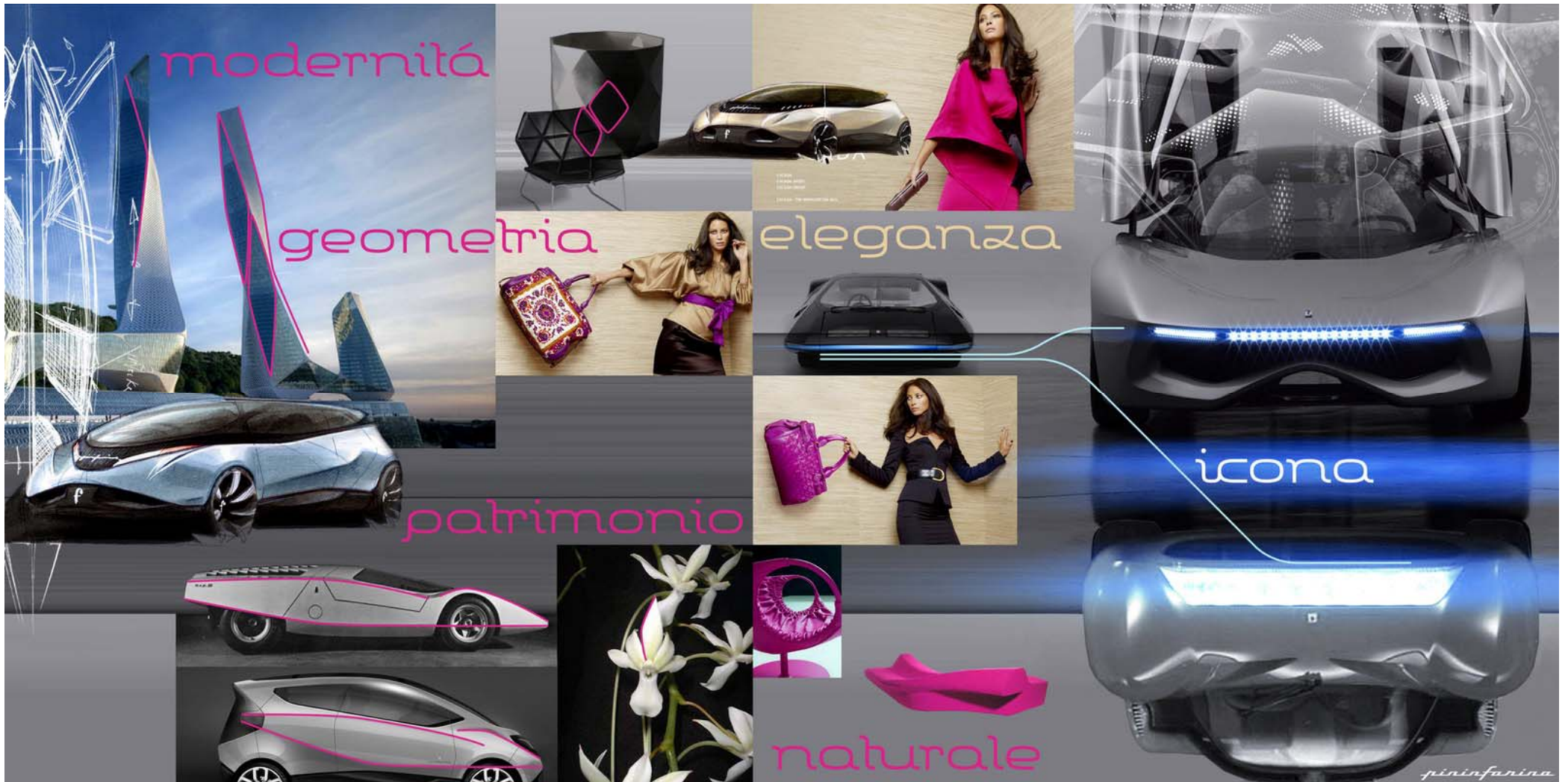

pininfarina

SKETCHES



pininfarina

SKETCHES

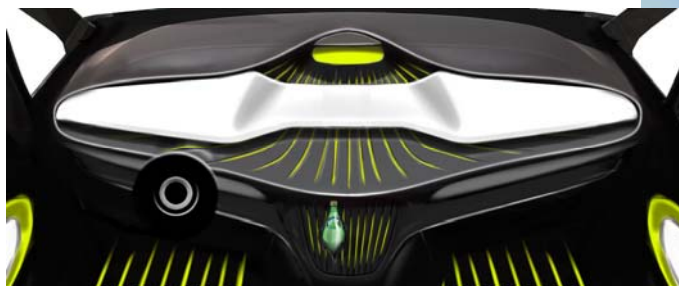
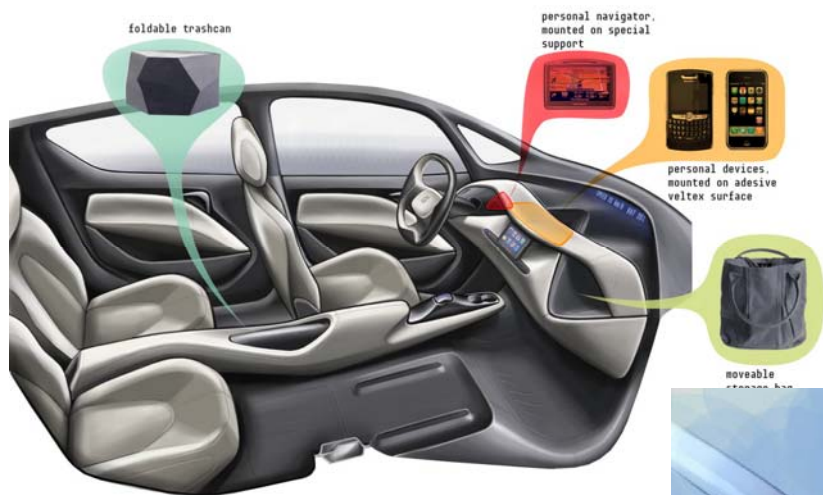

pininfarina

3D MODEL



pininfarina

MILLING

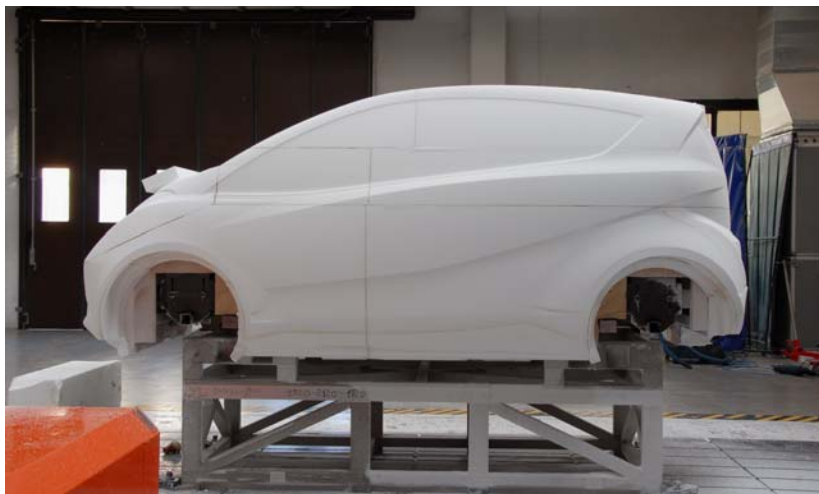

pininfarina

1:1 MODEL



pininfarina

1:1 MODEL



pininfarina

1:1 MODEL



pininfarina

WIND TUNNEL



pininfarina

INTERIOR MOCK-UP



pininfarina

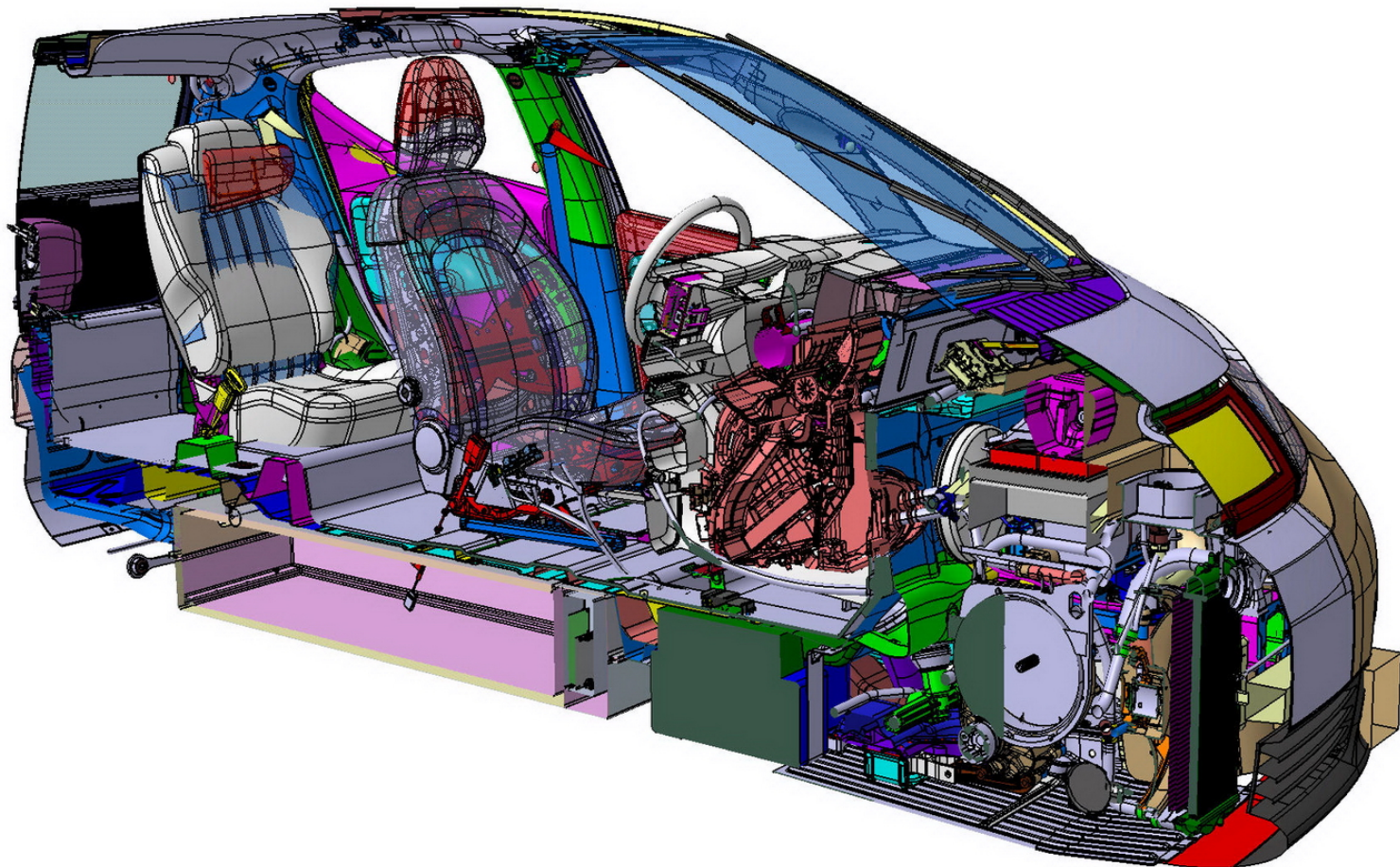

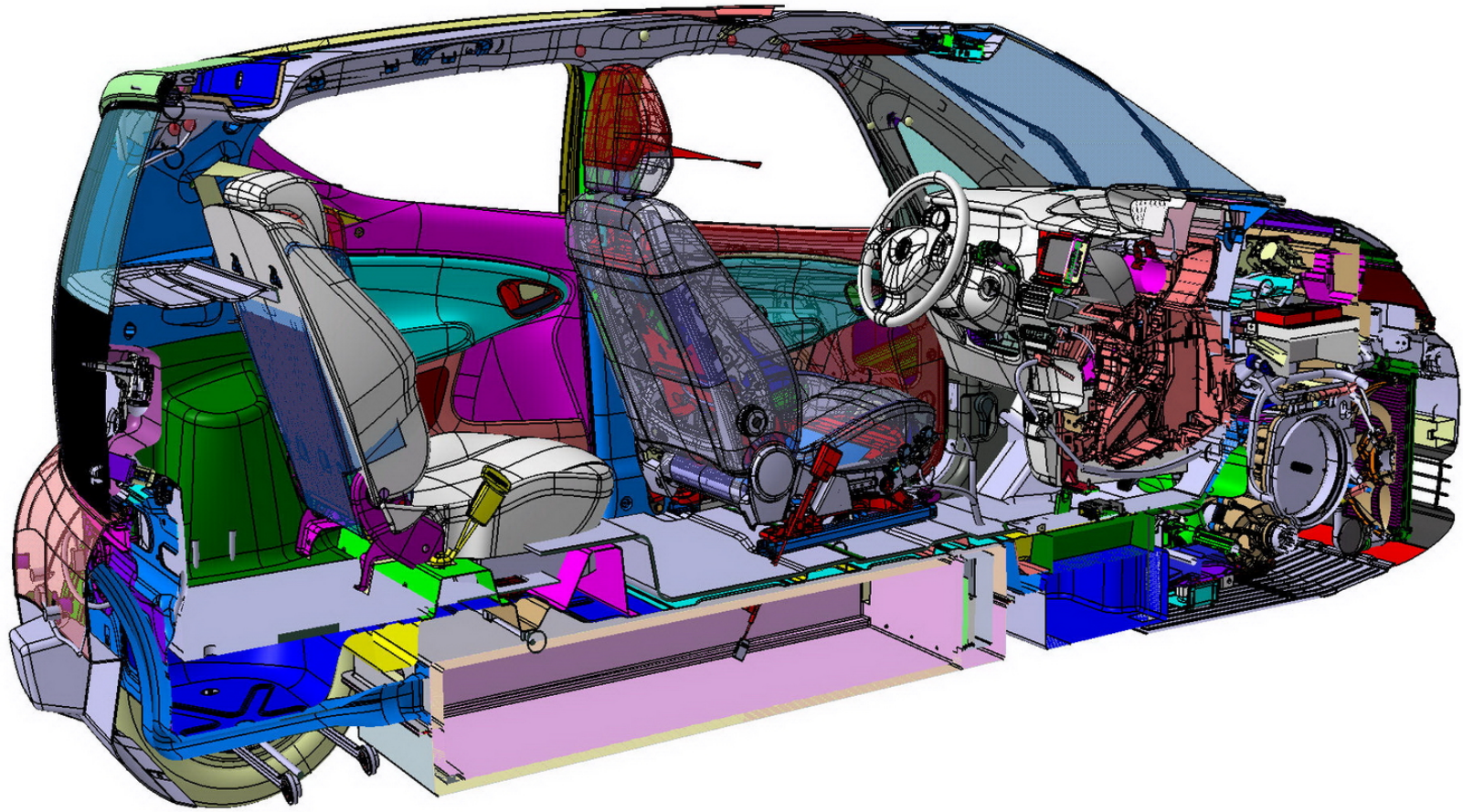

x
y

INTERIOR MOCK-UP



pininfarina

INTERIOR MOCK-UP



pininfarina

FINAL RENDERINGS



pininfarina

FINAL RENDERINGS



pininfarina

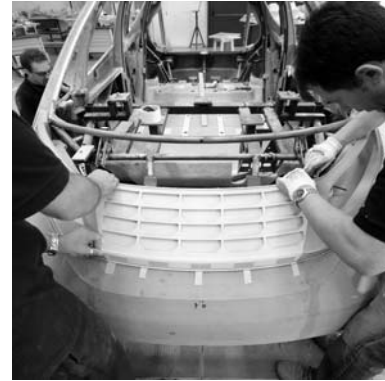

pininfarina



















“ To think, design, develop and produce cars isn't only an
affascinating mental journey or just a business choice...

It's also and above all a big social responsibility”

Andrea Pininfarina

Grazie!



pininfarina