

LMG Marin

Independent Naval Architects & Ship Design House



- Over 70 years in business
- Concept development - initial idea to production drawings
- About 15% of capacity used for R&D
- Focus on LNG, energy efficiency & renewable energy



Founders: Lund, Mohr & Gjaever-Enger

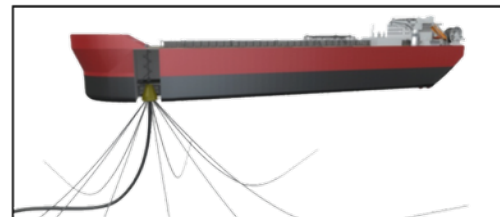
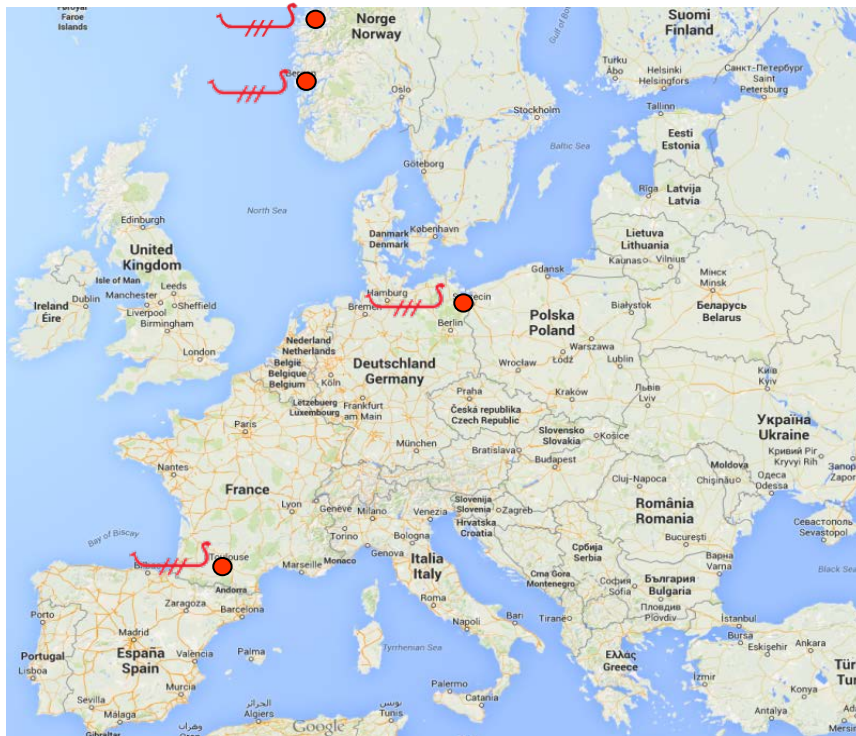

LMG Marin

Large scale LNG solutions

GraviFloat technology:

- Originally developed by LMG Marin
- Near shore gravity based platforms
- Turnkey delivery from shipyard
- Towed to location & piled to seabed
- Integrated jetty solution
- Building block principle
- Start small & grow with demand
- Alternative to onshore- or floating concepts

Available applications:

- LNG receiving, storage, re-gasification & import terminals
- Natural gas power generation & delivery to electric grid
- Natural gas liquefaction, storage & export terminals

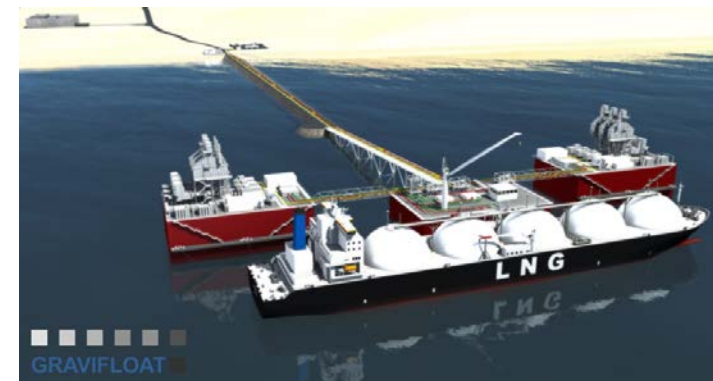
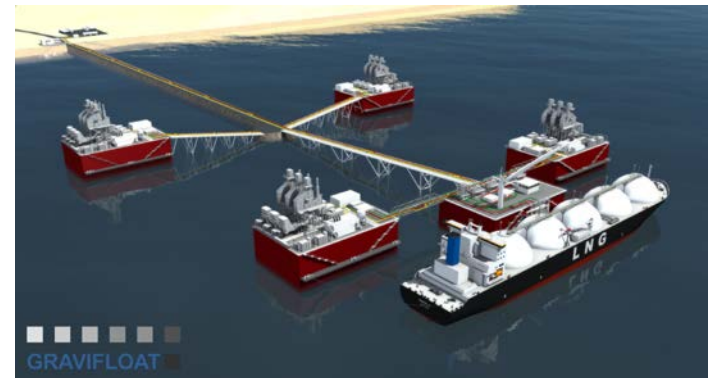
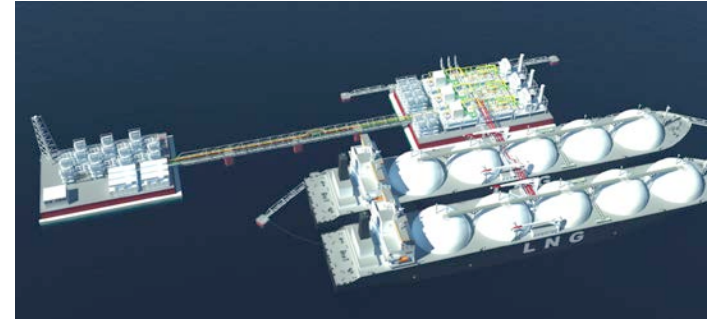

LMG Marin

Small scale LNG solutions

- LNG storage bunkering terminals
- Small scale LNG power generation
- LNG bunkering vessels
- LNG powered harbor tugs
- Small scale LNG carriers
- Containerized LNG logistics
- LNG distribution logistic studies

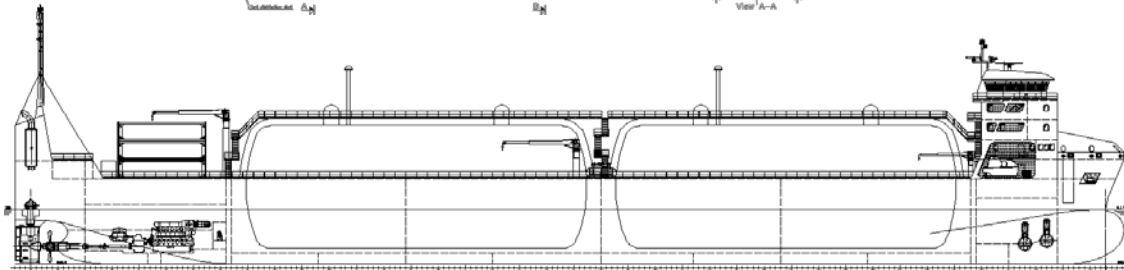
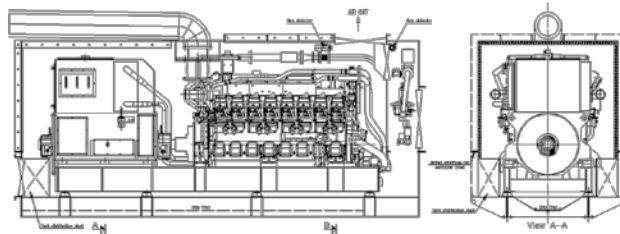
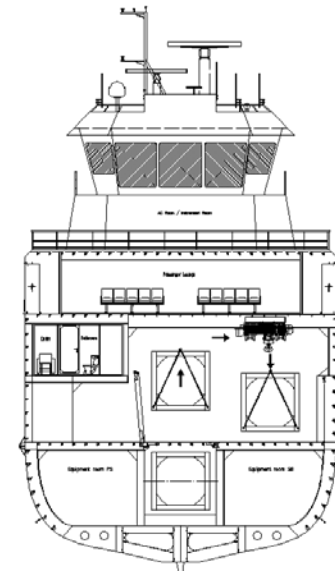

LMG Marin

LNG propulsion

- Double ended ferries
 - ROPAX vessels
 - Harbor tugs
 - LNG bunkering vessels
 - LNG carriers
 - Diesel to LNG conversions
 - LNG & battery hybrids
 - LNG ready solutions
 - 15 new-builds, 2 conversion & 4 LNG ready
 - Single fuel, dual fuel or hybrid solutions
 - ESD or inherently safe philosophy
 - LNG or CNG storage
-
- Gas related risk analysis
 - Route studies and optimization
 - Emission calculations

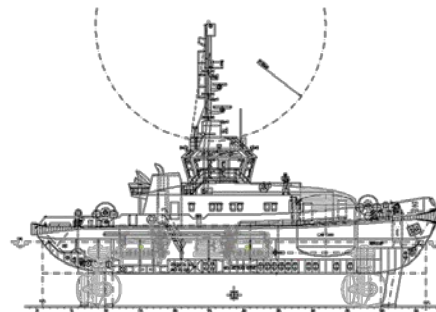
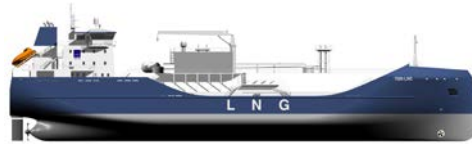

Energy efficiency parameters:

- Hull shape
- Light ship weight
- Propulsion
- Power generation & transmission
- Battery hybrid peak shaving
- Heat recovery & accumulation
- Hotel & auxiliary loads
- Route studies & optimization
- Energy consumption calculations

Renewable energy solutions:

- Biodiesel
- Biogas
- Battery electric plug-ins
- Hydrogen
- Hybrids (combinations)

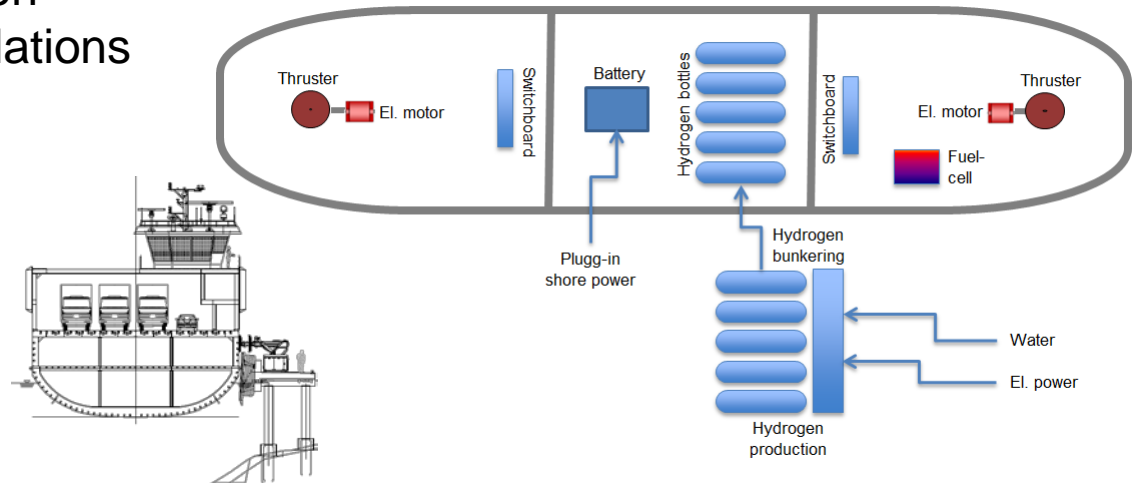
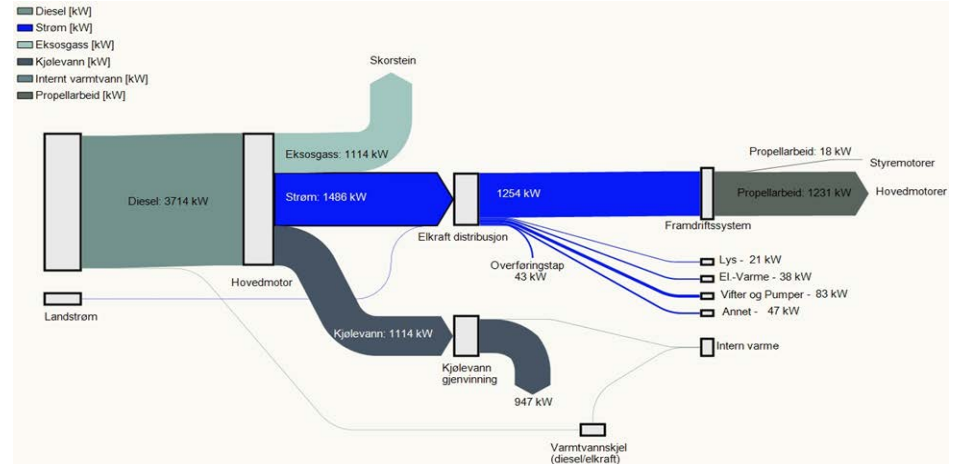

- General wide maritime experience & know-how
- Concept development for specific client needs
- Considering the whole maritime logistic chain
- Focus area:
 - LNG & natural gas applications
 - Energy efficiency & renewables



New Italian – Norwegian project:

- New gas ferry for Strait of Messina